



# ***RIDGEWAY***



## **Evorail Standard**

Guardrail has Evolved



# Introduction



- About Evorail Standard System
- Legislation & Hierarchy of Fall Protection
- Evorail Standard System
- Evorail extra components
- Installation procedures

# About Evorail



## Evorail freestanding system

Evorail has its very own aesthetically pleasing unique design which makes it the preferred system of choice in fall protection

Evorail system provides a permanent edge protection without the need to mechanically fix through the roofing membrane or roof structure, and provides full protection where access is required for public use, maintenance or emergency purposes.

The strength, stability and safety of Evorail is derived from our researched cantilever principal, which has engineered the need to drill and puncture the roof membrane out of the installation process. This avoids noise disturbance during installation and potential penetrative water damaged.

## Evorail is Robust

All of the systems fixings are grade A2 stainless steel, MAGNAtube (20 times the corrosion resistance of galvanised tube and eco friendly re-cycled weights give Evorail a minimum lifespan of at least 25yrs as a maintenance free system .

## Evorail is Modular

The system consists of pre-assembled uprights, 2.5mt rails and our slide on weight. The 2.5mt hand and knee rails are connected with the Evorail upright, which is fast, straightforward and easily adjustable to provide that perfect level finish. With no requirement for drilling, the system is easily mounted on whatever platform is required.

# More about Evorail



## Evorail is Versatile

The system has been specifically designed to fit all shapes and sizes of flat roofs, even circular designs. The system can also cope with level changes, roof falls and difficult designs, such as ductwork passing over the roof edge and cable trays/plant mounted at the roof edge.

## Evorail's added features

Evorail is manufactured with fixed rubber mats under the feet and sleek designed weight.

The rubber foot and weight are produced from re-cycled material, making them Eco-friendly.

The weight has Pre-moulded handles on the sides, enabling;

- Easy to carry
- Easy to assemble the weight to the system

## Membrane Protection

The rubber weights & foot are already membrane friendly; it is advisable for ultimate protection to add an additional piece of roof membrane under the foot and weight. This is not supplied with Evorail but is available as an optional extra if required.

# Legislation & Hierarchy of Fall Protection

## EN 13374:2013

All freestanding guardrails should be tested and designed to Temporary Edge Protection EN 13374 .

The Legislative Requirements:

- An edge protection system shall comprise at least a principal and an intermediate guardrail or intermediate protection, and it shall be possible to attached a toe board.
- The inclination of edge protection system class A shall not deviate from the vertical by more than 15 degrees.
- If an intermediate guardrail is provided, any gap shall be so dimensioned that a sphere of 470mm diameter will not pass through the protection.
- The distance between the uppermost part of the edge protection and the working surface shall be at least 1.0m measured perpendicular to the working surface.
- A load test of 0.30kN is applied horizontal from the rail and should not deflect more than 55mm.
- A load test of 1.25kN is applied vertically from the top rail and should not tip / fall over.



# Additional Compliance



## Toe Board Requirements:

- The upper edge of the toe board shall be at least 150mm above the working surface.
  - The toe board should be designed to avoid gaps between it and the working surface, preferably on a flat working surface.
  - If there are any gaps, a sphere with a diameter of 20mm shall not be able to pass through.
  - The general application for toe boards are;
    - To protect from falling tools of maintenance personnel.
    - Parapet is less than 100mm, therefore creating the gap between the knee rail and the working surface greater than 470mm.
- NOTE – for other situations, for example where the working surface is not flat, any gaps should be maintained as close as practical to 20mm.

# Legislative Hierarchy



The hierarchy for managing and selecting equipment for working at height is as follows.

Duty holders must ensure that:

- Where possible to avoid working at height.
- When working at height, work equipment is provided to avoid the risk of any fall.
- Where the risk of a fall cannot be avoided, use work equipment or other measures to minimise the distance and consequences of a fall should one occur.

When working at height, the duty holders must ensure when selecting the correct equipment.

- To use the most suitable equipment
- Give guardrails priority over personal protection such as harnesses and lanyards.
- Take account of the working conditions and the risks to the safety of all those at the place where the work equipment is to be used.

# EVORAIL Standard

Evorail standard is the most popular system sold from the Evorail range.

Even though classed as the standard system, it is far from a standard product. With its 10 degree incline and its aesthetically pleasing design it is in a league above the other standard systems on the UK and international market

Evorail standard can be purchased in;

- ✓ MAGNAtube
- ✓ Aluminium
- ✓ 304 & 316 Stainless Steel

Component / Product code

Long upright – ERSLU

Short upright – ERSSU

2.5mtr rail – ERAIL

Rubber weight - ERRUW

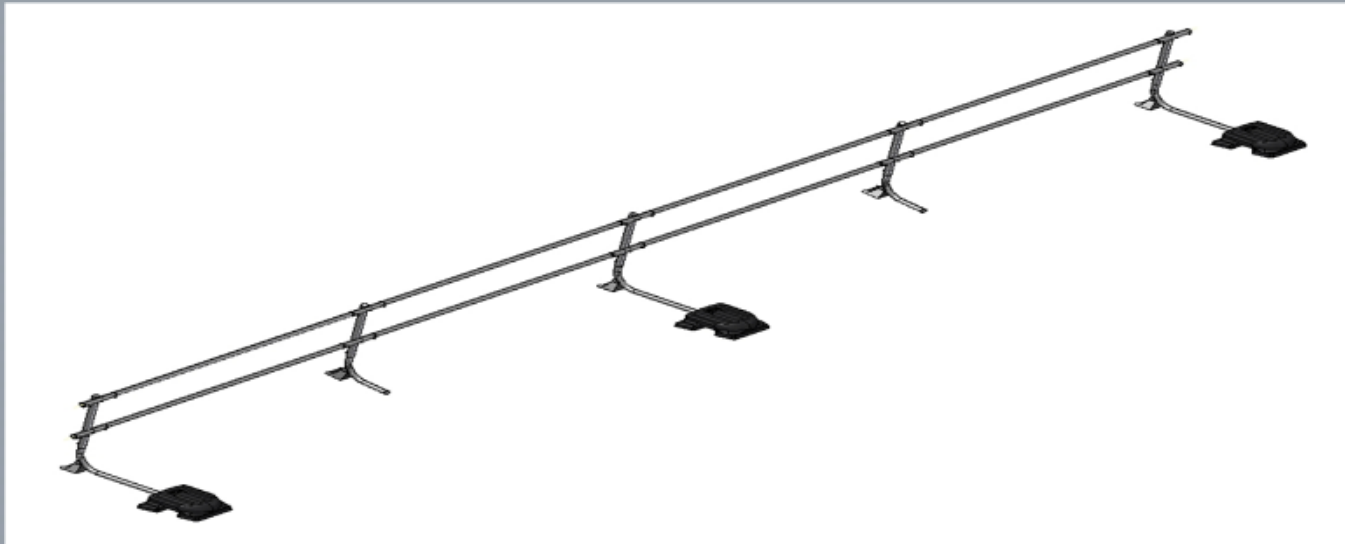



# Extra Components

## Freestanding End



A freestanding end is used when the system finishes and there is no option to secure the rails to a permanent fixture. A second weight is required to ensure the extra stability demanded at the end a run.

A freestanding end consists of;

- the D end
- an additional weight
- double weight connection bar

Freestanding ends are available in;

- ✓ MAGNAtube
- ✓ Aluminium
- ✓ Stainless Steel

D ends are utilized to suit all of the Evorail systems.

Components / Product codes

D end – ERDEN

Double Weight Connector – ERDWC

Rubber weight - ERRUW



# Extra Components

## Toe Boards



Evorail can be supplied with Toe boards as an option. They are fitted when the system has been erected incorporating a specially designed foot. The installation is a simple procedure using 4 no M8 bolts to fix the toe board to the foot.

Toe boards can be supplied in Galvanised and Aluminium.

Toe boards are available for the following systems:

- ✓ Evorail Standard – Galvanized
- ✓ Evorail Radius – Galvanized
- ✓ Evorail Standard – Aluminium
- ✓ Evorail Radius – Aluminium

Component / Product codes

Galvanized Toe board – ERTBG

Aluminium Toe board - EATBO

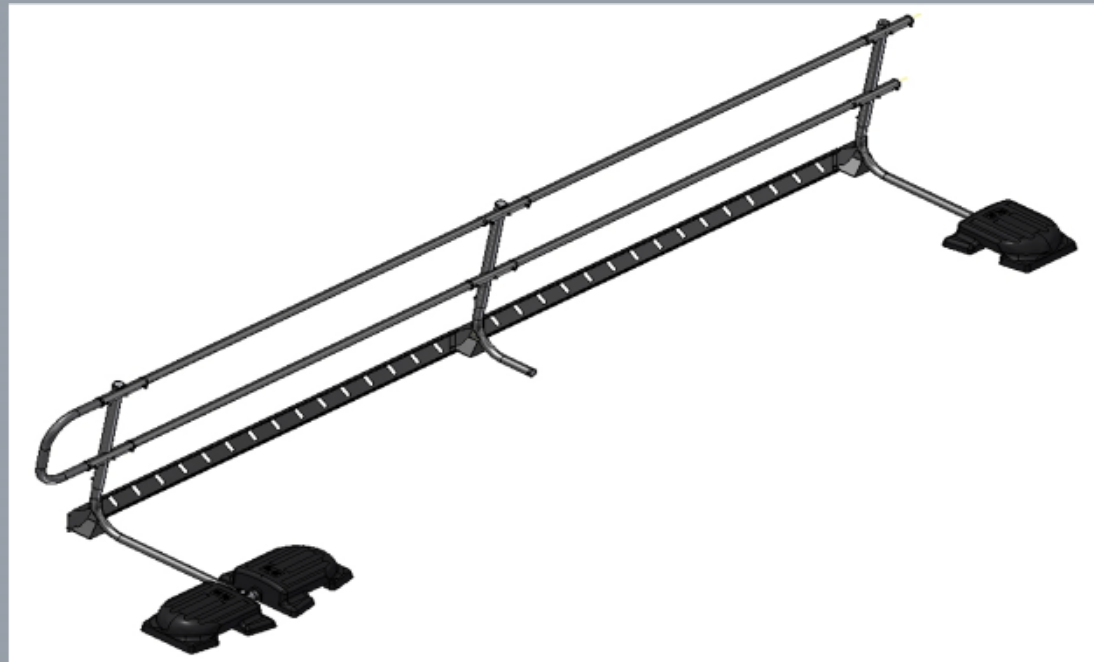

# Extra Components

## sweeping bend



A sweeping bend is the required component to accommodate design layouts with 90° corners.

Available in;

- MAGNAtube
- Aluminium
- Stainless steel

Component / Product code  
Sweeping bend - ERSWB

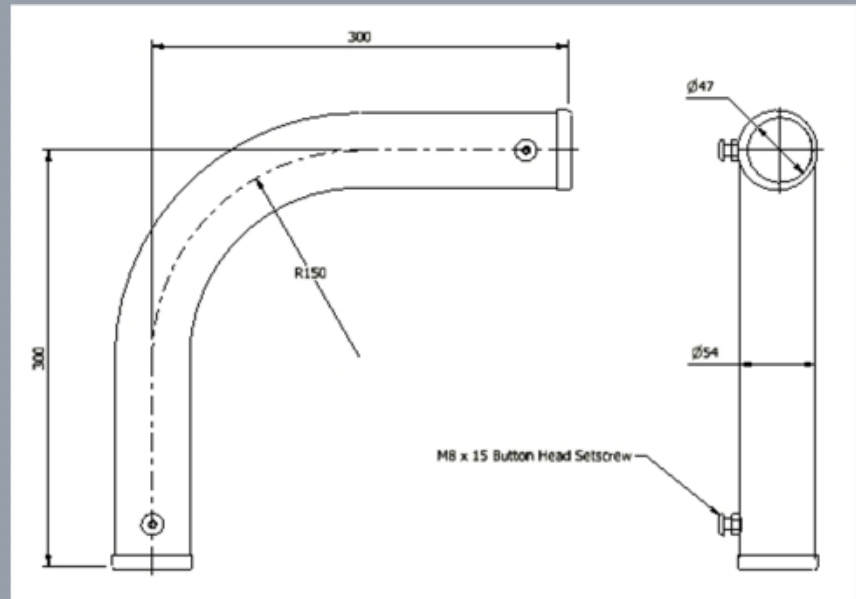

# Extra Components

## wall bracket



Wall brackets are the means to secure and connect the rail to a permanent fixture.

Available in;

- Galvanized
- Aluminium

Component / Product code

Wall bracket – ERWBK

Wall bracket - EAWBK

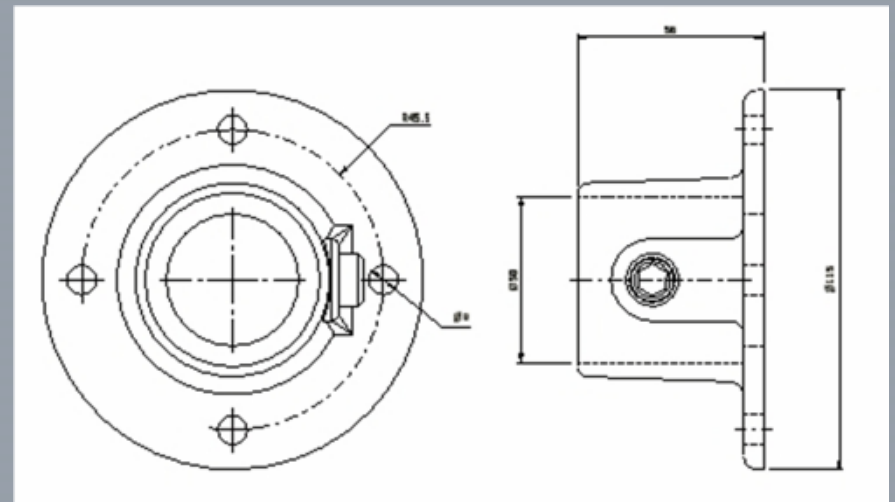
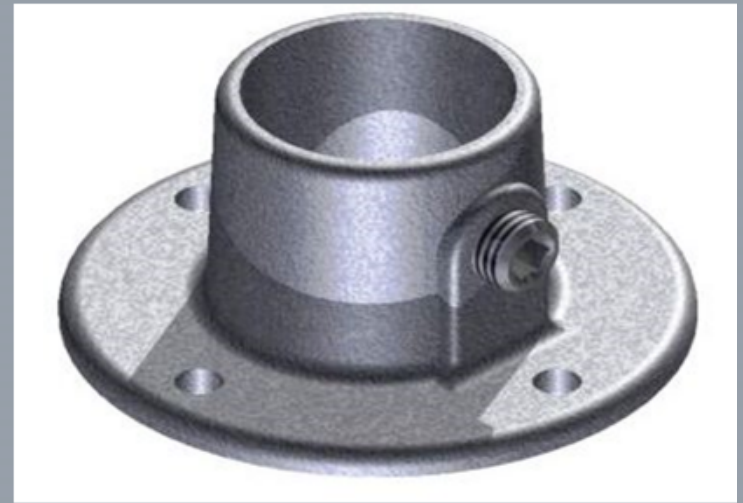

# Extra Components multi-bend



A Multi-bend is the component which required to accommodate design layouts with corners other than 90°

Can also be used to overcome changes in roof levels.

Available in;

- Galvanized
- Aluminium

Component / Product code

Multi-bends – ERMUB

Multi-bends – EAMUB

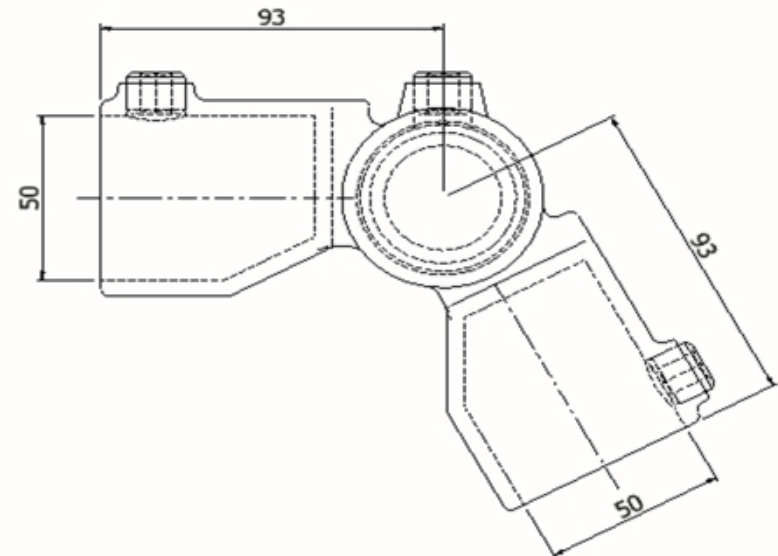
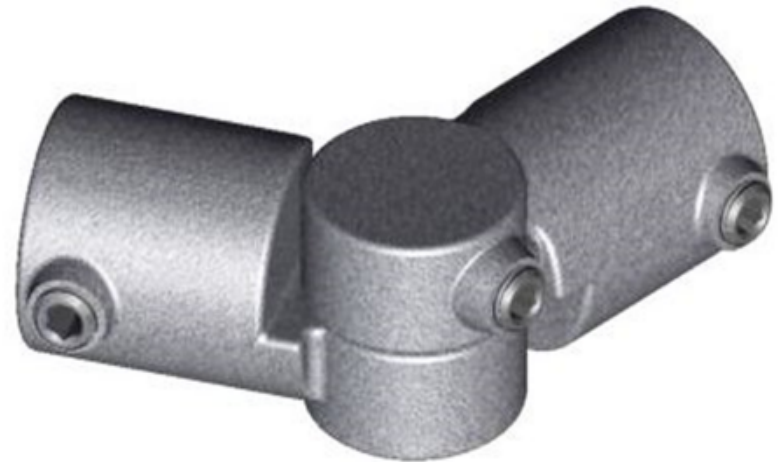

# Extra components

## T – piece



The T piece is used in conjunction with the double weight connector bar. And can be used to enable a variety of solutions on complicated roof layouts.

Available in;

- Galvanized only

Component / Product code

T – piece - ERTPI

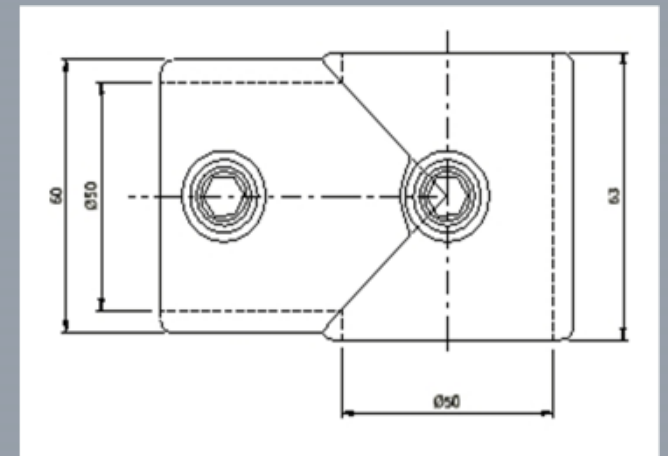

# Extra Components

## self closing gate

Self closing gate allows you to safely gain access through the Evorail systems, and to secure them behind you.

Available in;

- MAGNAtube
- Aluminium
- Stainless steel

Component / Product code

Self closing gate – ERSWG

Self closing gate – EASWG

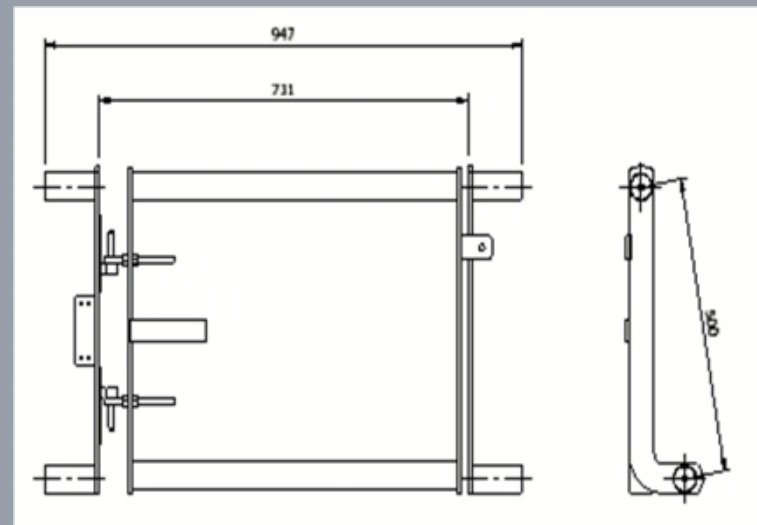
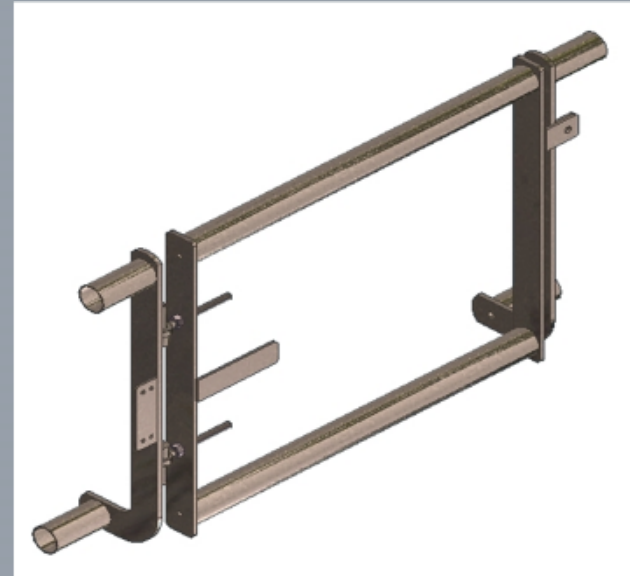

# Installation Guide

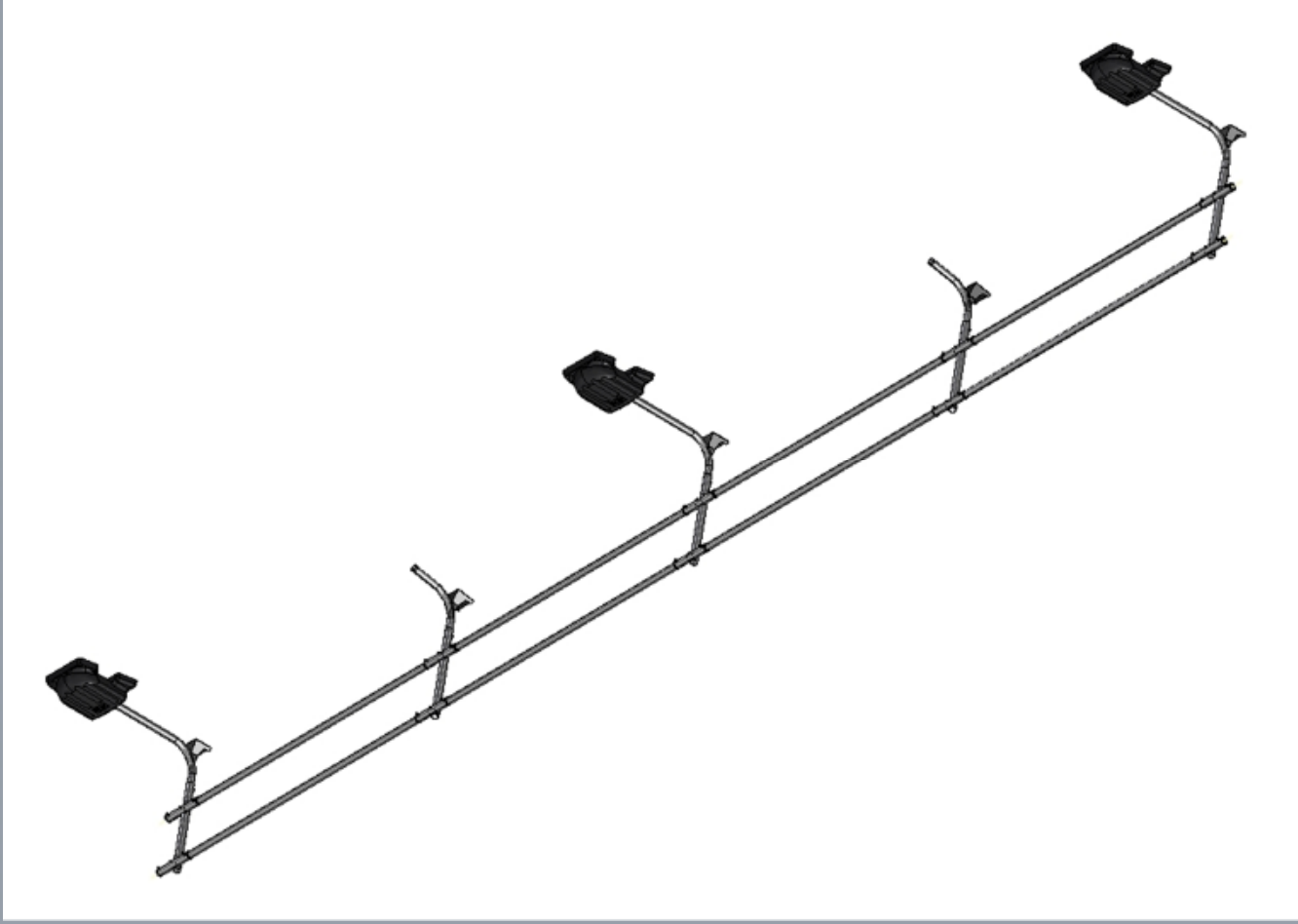



# Tools required for Evorail Standard



Tools required to install Evorail (not supplied)

- ✓ 5mm allen key
- ✓ 8mm allen key
- ✓ Hacksaw or electrical cutting machine
- ✓ Battery drill
- ✓ Suitable drill bit to fix wall bracket (6mm masonry or 5mm steel bit)
- ✓ 13mm ratchet & spanner
- ✓ Marker pen
- ✓ Spirit level

# Planning your layout



- There are generally 2 ways of delivering the components onto the roof:
  - Manually
  - Crane or hoist
- Once all the components are on the roof, you can start planning the layout and the erection of Evorail.
- Ensure the roof area where the system is to be installed is clear from debris including any gravel or stones.
- When possible install the system at **least** one metre from the roof edge.
- If installing on a Membrane roof, it's recommended to use additional membrane pads under the foot and rubber weight. This gives extra protection to the roof membrane.
- Before you start to layout the system, plan your starting point. If there's a fixed end or freestanding end that is generally the best place to start, and work from left to right.
- If the layout connects back to itself i.e. a square. Start at one of the corners with a long upright, approximately 1m in from the corner.
- When your starting point has been decided, begin to layout the 2.5mt rails on the roof where the system is going to be erected, when all are laid out begin to place the uprights at the joints of the rails.
- The uprights should be laid out alternately, long upright – short upright - long upright and so on. Usually starting with the long upright first.

# Layout Continued.....



- All rails and uprights should now be in position, next place the rubber weights with the long uprights. The weights should be spaced every 5mtrs, if there are any freestanding ends two (2) weights should be placed at this point.
- All sweeping bends should be placed at the appropriate corners.
- Now all the system is laid out and ready to be erected. Go to your starting point. Place the long upright in position and slide the knee rail into the upright. Secondly slide the top rail into the upright. Holding the rails horizontal, slide over the short upright, placing the rails in at the same time.
- tighten up the M8 fixings with your 5mm allen key. You now have the first 2.5m section in place.
- Take the rubber weight and slide on to the end of the long upright, there is a grub screw in the top of the weight. Ensure this is tightened, do not over tighten.
- The 2.5m run is light enough should require to re-adjust the position. It's advised at this stage to double check everything is correct with the alignment.
- Take the next rail and slide into the short upright knee rail socket, take the other rail and insert the top rail. A long upright then slides over the rails, tighten the bolts and place weight on the end of long upright.
- Continue this procedure until the run ends or you come to a corner.

# Installation Continued.....



## ➤ A CORNER

- When you come to a corner, place the 2no rails in the upright pointing towards the edge of the roof.
- Place your next upright adjacent to the rails in the position / line it will be in on the return from the corner.
- Place the sweeping bend on the upright and rails and mark on your cut lines accordingly to the sweeping bend. (approximately 100mm into the bend will suffice).
- Take both rails out and find a safe and suitable place to cut the rails. It is advisable to mark up your cut rails to avoid them getting mixed up.
- Once cut and marked, place the rails back into the upright. Slide the sweeping bend over the rails with bolts on the bend pointing towards the roof and tighten 2no bolts.
- The off cut from the top rail needs to slide in the bottom sweeping bend, and the off cut from the knee rail needs to slide into the top sweeping bend. This keeps the rails in line when you come to connect the upright. ( if the rails are not in line on the return of the corner, the rails have most likely been mixed up).
- Slide on the next upright and carry on the procedures as before.

# Installation Continued....



## ➤ FREESTANDING END

- There are 3 items which complete a freestanding end.
- A D end will be supplied to slide into the long upright on the finishing side.
- The D end is 500mm long and can be cut down if required.
- Tighten bolts up to secure D end
- Two (2) weights are required with a freestanding end, there will be a double weight connecting bar supplied which fixes on the end of the long upright by a T piece.
- One (1) weight slides onto the end of each side of the bar.
- Tighten grub screw in weights.

## ➤ WALL FIXED END

- When the rails can be fixed into a wall , a wall bracket will be supplied.
- There are four(4) fixing holes in the bracket, use suitable fixing for the 6mm hole.
- Into brick or concrete we advise M8 x 50's JAB fixings or 6mm threaded bar resin fixed.
- Into cladding we advise pop rivets or tek screws to be used.
- Use a spirit level to ensure the fixed rails remain horizontal
- The last upright can end on a short or long upright when using the wall brackets, do not exceed the 2.5mtr span.

# Installation Continued....



## ➤ ON COMPLETION

- When the Evorail system is erected. The system can be adjusted to accommodate modest rise and falls in the roof alignment.
- If levelling is required, unscrew the bottom bolt on the top section of the upright and adjust accordingly.
- Re-tighten the bolt once level
- Walk round checking the system is level and in line and double checking all the bolts and fixing are tight and secure.

# Installation Continued....



## ➤ TOE BOARDS

- Toe boards will be supplied to fix straight onto the foot of the system.
- Toe boards should only be used after Evorail has been erected.
- The hole centres of the toe board line up with the holes in the foot when the uprights are correctly positioned and butt up to the 2.5 mtr rails.
- Slots are manufactured into the toe board to allow for any slight dimension variation .
- M8 bolts are supplied with toe boards – four (4) per toe board.
- Internal corner – a hacksaw will be required to notch out the channel section of the toe board, this will allow the toe board to fold and continue around the corner.
- External corner – a hacksaw will be required to cut the toe board in two (2) pieces to the correct measurement. A connection plate will be supplied and you will require a drill to re-drill the toe board.



# RIDGEWAY

**evo**  
SAFETY SOLUTIONS

Belfast: +44(0)28904544599  
Ashbourne: +353(01)8027173  
Email: [info@ridgewaysiteproduct.co.uk](mailto:info@ridgewaysiteproduct.co.uk)

Visit our website at:

[www.ridgewaysiteproducts.com](http://www.ridgewaysiteproducts.com)

